

TrueNet[®]

FL2000 Termination/Splice Empty Panel

Issue 2

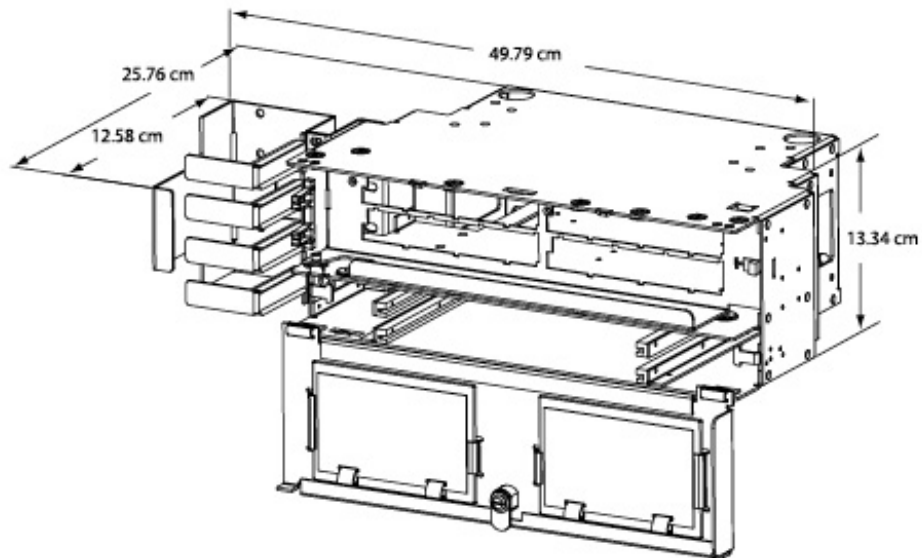

These can be mounted on a 19" rack or in cabinets, with a standard 12.7cm recess. There are alternative mounting kits, including a wall mounting option. They are hinged on the left front side for complete access to the interior of the termination section.

These can be quickly and easily configured, utilising the 6pak assemblies (ordered separately).

There is a complete line of accessories available including locks for security.

Features:

- Locking or latching door
- Within panel splice wheel
- All front access, modular left angle 6 packs
- Mounting
 - 19" (48.26cm) EIA racks or cabinets, standard 5" (12.7cm) recess
 - Wall mounting option available
 - Other mounting kits available
- Hinged on left front side ¹ for complete access to interior of termination section
- Ability to quickly and easily configure, utilising the 6pak assemblies (ordered separately)
- Complete line of accessories including locks for security
- Uses ADC splice wheels or splice decks

¹ Right hinged also available

SPEC SHEET



adckrone.com/au • 1800 801 298 • helpdesk.au@adckrone.com

TrueNet®

FL2000 Termination/Splice Empty Panel

Ordering Information

Description	Quantity	Panel Height	Product No.
Termination/Splice Panel, black			
12-position	Box of 1	8.89cm (2RU)	FL2-12TS350-B
24-position	Box of 1	13.34cm (3RU)	FL2-24TS525-B
48-position	Box of 1	22.23cm (5RU)	FL2-48TS875-B
72-position	Box of 1	35.56cm (8RU)	FL2-72TS140-B
96-position	Box of 1	44.45cm (10RU)	FL2-96TS175-B
Splice Wheel with Splice Chip			
12-position heat shrink fusion	Box of 1		FST-DRS12-HS
24-position heat shrink fusion	Box of 1		FST-DRS24-NT
Splice Deck with Splice Chip			
12-position heat shrink fusion	Box of 1		FL2-RSPLCE-HS-B
24-position heat shrink fusion	Box of 1		FL2-RSPLCE-NT-B
Accessories			
Flush Mount Kits			
Allows recess mounting, and kit includes: new vertical cable guide and mounting flanges.			
	Box of 1	2RU	FL2-FLMT0350-B
	Box of 1	3RU	FL2-FLMT0525-B
	Box of 1	4RU	FL2-FLMT0700-B
	Box of 1	5RU	FL2-FLMT0875-B
	Box of 1	6RU	FL2-FLMT1050-B
	Box of 1	8RU	FL2-FLMT1400-B
	Box of 1	10RU	FL2-FLMT1750-B
Cable Clamp Kits			
Outer diameter 0.51cm to 2cm	Kit		FL2-ACC007
Outer diameter 1.8cm to 2.5cm	Kit		FL2-ACC021
Cable clamp kit for 12 fibre capacity panel only	Kit		FL2-ACC033
Bonding/Grounding Kit			
Bonding/Grounding Kit	Kit		FL2-ACC006

SPEC SHEET



www.adckrone.com/au

AUSTRALIA 2 Hereford Street, Berkeley Vale NSW 2261
Mailing Address: PO Box 335, Wyong NSW 2259, Australia
Sales Support: 1800 801 298

www.adckrone.com/nz

NEW ZEALAND 2 Nevis Street, Petone, Wellington
Mailing Address: PO Box 38-177, Wellington Mail Centre 6008, New Zealand
Sales Support: 0800 657 663

ADC Telecommunications, Inc., P.O. Box 1101, Minneapolis, Minnesota USA 55440-1101
Specifications published here are current as of the date of publication of this document. Because we are continuously improving our products, ADC reserves the right to change specifications without prior notice. At any time, you may verify product specifications by contacting our headquarters office in Minneapolis. ADC Telecommunications, Inc. views its patent portfolio as an important corporate asset and vigorously enforces its patents. Products or features contained herein may be covered by one or more U.S. or foreign patents. An Equal Opportunity Employer

FL2-XXTSXXX-B / Issue 2 © 2010 ADC Telecommunications, Inc. All Rights Reserved.